

General Notes:

1. Fastener Spacing Tables apply to Washer Head (CS) Construction Screws manufactured by U2 Fasteners and recognized in UES Evaluation Report 454.
2. Fastener Spacing Tables based on 2018 National Design Specification (NDS) 12.3 Reference Lateral Design Values.
3. Uniform deck live loads (40 psf & 60 psf) and dead loads (10 psf max) per ASCE 7-10 typical for residences.
4. Tabulated fastener size and spacing represents minimum installation to resist dead & live loads shown.
5. Wind and seismic loads are not considered in the Tabulated values and to be designed separately by others.
6. The minimum fastener end and edge distances and spacing shall be in accordance with NDS requirements, Table 5 of UES ER-454, or engineered wood product manufacturer recommendations, whichever is more restrictive.
7. Where installation creates splitting of the wood, holes are required to be pre-drilled in accordance with the NDS for wood-screw installation.
8. The U2 fasteners shall be installed only in exposure conditions described in Table 6 of UES ER-0454. Reference lateral design values in the Tables are for allowable stress design and shall be multiplied by the applicable adjustment factors specified in the NDS.
9. Fastener Spacing Tables apply to Number 2 Grade or better Wood Species shown in Table 1.

Table 1

Wood Species	Specific Gravity (SG)
(SPF) Spruce-Pine Fir	G=0.42
(HF) Hem Fir	G=0.43
(DFL) Douglas Fir Larch	G=0.50
(PSL) Parallel Strand Lumber	G=0.50
(LVL) Laminated Veneer Lumber	G=0.50
(LSL) Laminated Strand Lumber	G=0.50
(SP) Southern Pine	G=0.55

10. Specific Gravity (SG) shall be the assigned specific gravity for sawn lumber or wood structural panels per NDS Table 12.3.3A, or the engineered wood product equivalent specific gravity in applicable evaluation report.
11. All lumber exposed to weather, water, concrete, masonry, fungus, termite or any type of decay to be pressure treated / wolmanized and/or protected per code and installed per manufacturer's instructions.
12. Screws shall be installed straight into the side grain of the wood main members with the screw axis at a 90-degree angle to the wood fibers.
13. Tables apply to deck ledger boards (1-1/2" min. thickness) attached to wood rim joists (1-1/2" min. thickness) having sufficient capacity to support all imposed loads.
14. No building materials to be installed between the deck ledger board and the rim joist.
15. All lumber shall have a moisture content of 19% or less at time of installation.
16. All lumber / connections to be designed by a Register Design Professional acceptable to the Authority Having Jurisdiction (AHJ).
17. Special inspections per Chapter 17 of the International Building Code or locally adopted codes, as applicable.

Example:

Ledger: 2x10 Southern Pine
 Rim Joist: 2x10 Douglas Fir Larch
 Deck Joist Span: 10 feet
 Dead Load: 10 psf
 Live Load: 40 psf

For fastener sizer and spacing:

Enter Table 2a for dry conditions or Table 2b for wet conditions
 Verify minimum ledger / rim joist thicknesses are greater than 1-1/2"
 Verify conditions in general notes are satisfied including minimum end / edge distances.
 For dead load of 10 psf or less (in Table footnote), and,
 For live load of 40 psf (in Live Load column), and,
 For wood species with lowest specific gravity (i.e. SG = 0.50 / DFL-PSL-LVL-LSL for Douglas Fir Larch), and,
 For deck joist span = 10 ft, per table:
 Use: CS – 5/16 x 4" at 10-inches on center for dry or 7-inches for wet conditions.

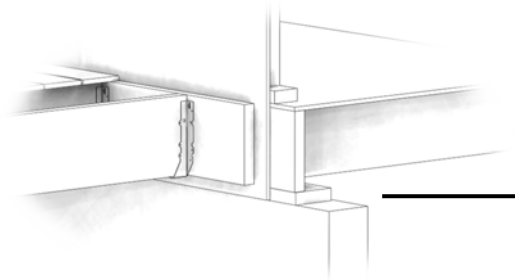

Table 2 a

Fastener: 5/16 x 4"			Joist Span (ft)				
			6	8	10	12	14
Live Load (psf)	Wood Species	Fastener Shear Capacity	Fastener Spacing (Inches)				
40	SG =0.42 / SPF	156	12	9	7	6	5
40	SG =0.50 / DFL-PSL-LVL-LSL	216	17	12	10	8	7
40	SG =0.55 / SP	257	20	15	12	10	8
60	SG =0.42 / SPF	156	8	6	5	4	3
60	SG =0.50 / DFL-PSL-LVL-LSL	216	12	9	7	6	5
60	SG =0.55 / SP	257	14	11	8	7	6

NOTE: 1. Deck Dead Load (psf)=10

Table 2 b (wet service)

Fastener: 5/16 x 4"			Joist Span (ft)				
			6	8	10	12	14
Live Load (psf)	Wood Species	Fastener Shear Capacity	Fastener Spacing (Inches)				
40	SG =0.42 / SPF	109	8	6	5	4	3
40	SG =0.50 / DFL-PSL-LVL-LSL	151	12	9	7	6	5
40	SG =0.55 / SP	180	14	10	8	7	6
60	SG =0.42 / SPF	109	6	4	3	3	2
60	SG =0.50 / DFL-PSL-LVL-LSL	151	8	6	5	4	3
60	SG =0.55 / SP	180	10	7	6	5	4

NOTE: 1. Deck Dead Load (psf)=10
2. Wet service factor 0.7



Scan this QR Code for IAPMO ER-454.

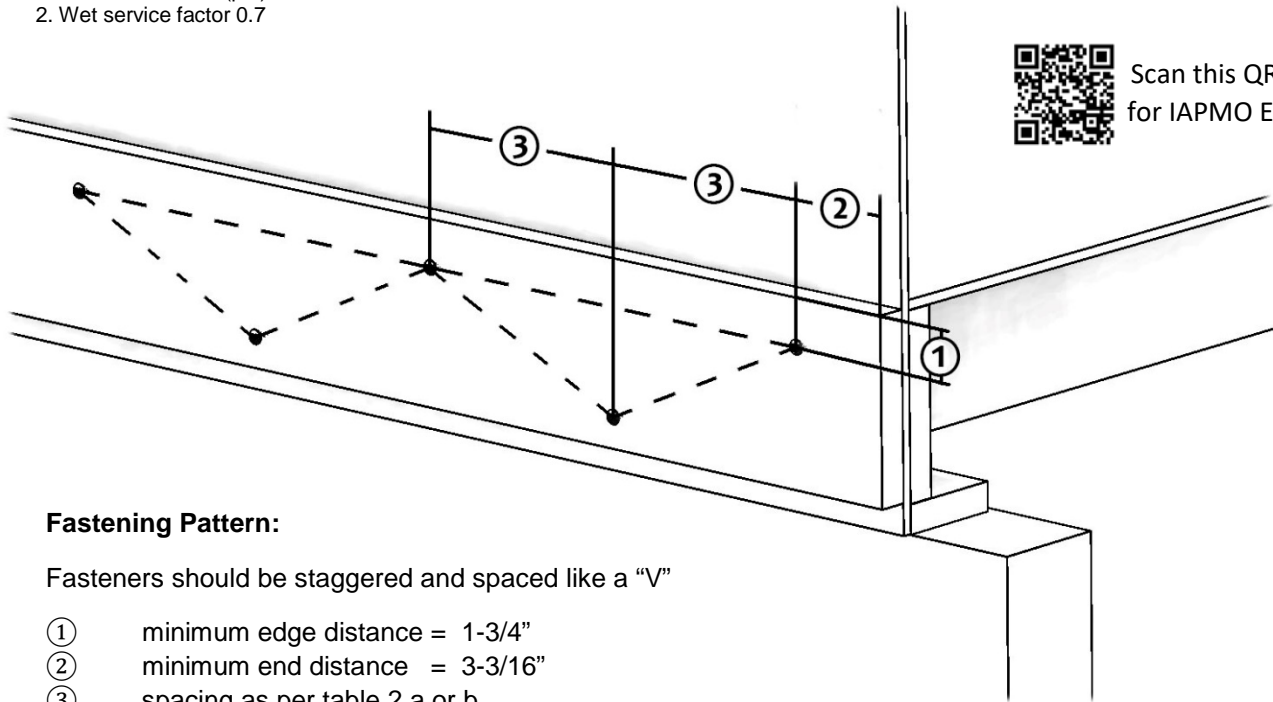

Fastening Pattern:

Fasteners should be staggered and spaced like a "V"

- ① minimum edge distance = 1-3/4"
- ② minimum end distance = 3-3/16"
- ③ spacing as per table 2 a or b